

Medical Gas Area & Main Alarm Panel (Xanadu Model)

An innovative 12" touch screen area & main alarm panel monitors and displays the local & remote (Manifold Systems) medical gas information as required by the latest additions of NFPA99, EN ISO 7396-1 and HTM02-01.

The new Silbermann touch screen alarm panel incorporates state of the art Hi security technology, protecting the information displayed and transmitted, from malicious attacks.



Features

- LCD 12" touch screen display.
- Display of **1-6 local gases/ gauges** alarms **together** with **1-18 remote digital** alarms on screen.
- Aesthetics & smooth design without buttons for infection control.
- Secured Ethernet based network communication between all units.
- Unique secured authentication of each unit to avoid fake/masking of alarms.
- Remote viewing through mobile device or remote computer.
- Gas specific sensor with DISS nut and nipple to avoid mechanical cross connection.
- For Future Use- disables a gas alarm until the gas pipeline infrastructure is complete.
- Multi linguistic- Supports English, Spanish, Russian, Arabic & Chinese.
- Commissioning for local gas/ gauges - Enables to identify gas leaks before commission.
- Gauges color trend arc showing the gas pressure status.
- Expandable digital menu- Menu expands automatically in case of an alarm within it in order to show that alarm.
- Adjustable digital alarms color (Red/ Yellow).
- Enable/ Disable of digital alarm.
- Adjustable digital alarm type (NO/ NC).
- Automatic adjustment of screen brightness (day & night mode).
- Self diagnostics with error display for problem identification.
- Event logging, recording all alarms and panel activities.
- Periodical maintenance alert.
- Customizable text for digital alarms & panel location.
- Remote monitoring dry contacts of gas pressure alarm condition including: High & Low alert, Below Min alert, Any Alarm.
- Hinged panel opening for easy installation and maintenance.
- On-site adjustment of HI and LOW set-points for each Gas & gas units.
- Highly accurate solid state pressure piezo-resistive transducer.
- Built-In relay for remote annunciator applications.
- Gas specific digital sensors mounted locally or remotely, up to 1500m, utilizing 22 gauge twisted pair.
- Wifi communication available.
- Remote monitoring (Via TCP/IP Modbus) through building management system available.

Applicable Standards

- Medical Gas Systems: NFPA99, EN ISO 7396-1 & HTM02-01 requirements.



Specifications

- The digital 12" touch screen area & main alarm system shall be of Silbermann's type.
- Alarm Panel shall be capable of accommodating up to six services & 18 digital alerts. The sensors shall be capable of local or remote mounting.
- Customizable language and gas badges (ISO/NFPA colors) during setup process.
- Each transducer shall be electronically gas specific to avoid wiring cross connection.
- Each gas service shall have a unique display indicating the on-line measured pressure/vacuum.
- Each gas service shall have a trend bar for showing the pressure trend. (Green - Normal, Yellow - Caution, Red - Hi or Low). In the case of an alarm the red light will flash and the alarm will sound. Canceling the alarm by the mute button will stop the audible alarm but the red light will continue to flash until failure is fixed.
- TEST & SILENCE touch buttons shall be easily accessed for operating and testing the unit.
- Adjustable repeat alarm (15 or OFF. Also 15 seconds for convenient maintenance).
- Selected gas pressure units: PSI, kPa or BAR.
- Selected vacuum pressure units: kPa, mmHg cmHg.
- Alarm buzzer level adjustable : 70,80,90 dB
- Adjustable Hi and Low set points (+/-20% of normal pressure).
- Input power shall be 100VAC to 230VAC, 50-60Hz
- Optional backup battery.



Dimensions [mm]

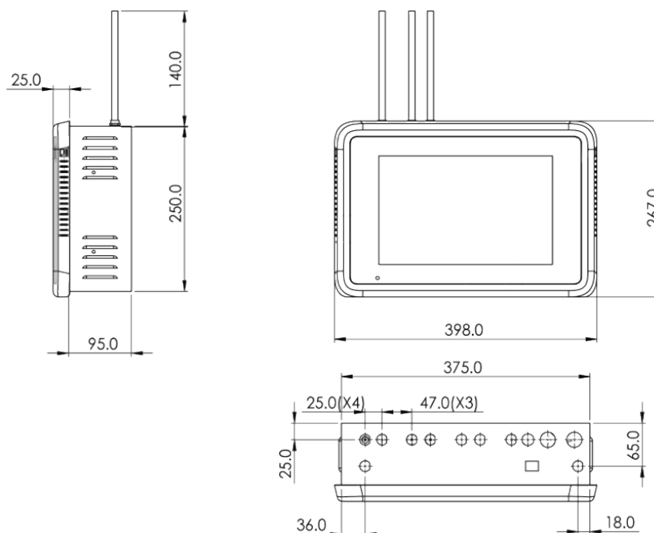

Catalogue Numbers

No. of Gases	Cat No. (One digital Group- up to 9 alerts)	Cat No. (Two Digital Groups- up to 18 alerts)
1	7182528	7182533
2	7182525	7182530
3	7182531	7182526
4	7182527	7182532
5	7182524	7182529
6	7182589	7182515

Distributed By: